

General System Description

(Some details may vary depending on the installation)

Overview

The AQ301 system consists of a dual compartment panel designed to control the boiler water quality of a steam boiler installation the unit is equipped with a frame, which allows for the mounting of dosing pumps and storage of the in-use chemical drums.

This equipment takes a sample of the boiler water at predefined intervals and measures the:

- pH
- Electrical conductivity
- Dissolved oxygen (optional)

Also measured is:

- The quantity of water fed to the boilers
- Feed water temperature

From these measurements the AQ301 panel controls the chemical dosing rate and operation of the blow down valve.

With a AQ301SBD version the unit can manage blow down and heat recovery for small boilers by blowing down through the units integral cooler and returning the cooling water back to the hotwell as make-up. If this version is used it is important that the cooling water is from the same source as the make-up water

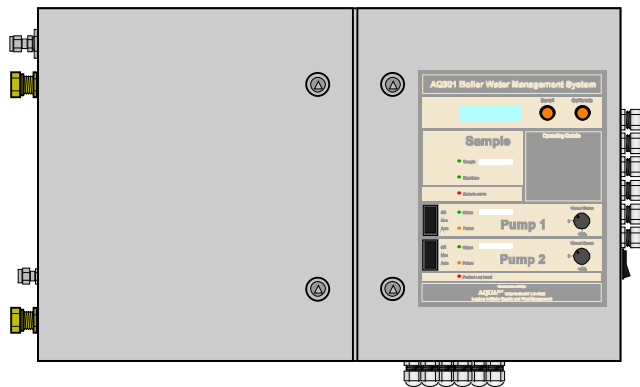

The measured sample is discarded but the cooling water is returned to the hotwell in order to avoid heat wastage.

The Aquanet 301 panel contains the necessary functions to raise alarms whenever a pre-configured alarm threshold is passed. Alarms are raised either through a PC running Aquanet software or via an SMS message to a mobile phone.

Electrical power requirement is single phase, 220Vac 50/60 Hz 10 amps maximum.

System Piping and Installation

Boiler sample

Boiler samples are taken from the boilers normal manual sample point via an isolating ball valve, strainer and 6mm stainless steel sample lines.

Cooling Water

Only during a boiler sample does a solenoid valve supply cooling water to the AQ301 cooler.

Cooling water lines are 12-15mm. Stainless steel or Copper is suitable

Chemical Dosing Lines

Chemical dosing lines are 6mm Stainless Steel as standard, however 6mm plastic dosing pipe (PE) is acceptable if preferred. The dosing arrangement is BWT dosed in the boiler feed line close to the boiler.

Oxygen scavenger dosed in the boiler feed line close to the hotwell.

Blowdown Valve

Chemical balance of the boiler water is achieved partly by controlled operation of the blowdown valve.

The blowdown valve is a DN20 PN40 electrically operated fail safe valve.

It is installed on the boilers scum line manual blowdown point and has the following features.

- a) Fails closed if there is a power cut whilst open.
- b) Max throughput
10 bar boiler 32bar boiler
10mm stroke 570 kg/hr 940 kg/hr
20 mm stroke 1500 kg/hr 1800kg/hr
- c) Allows manual operation.

Flowmeter

The main flow to the boiler is measured with a normal impeller type flowmeter on the boiler's feed line. The flow signal is an important control input to the panel for auto control of the oxygen scavenger.

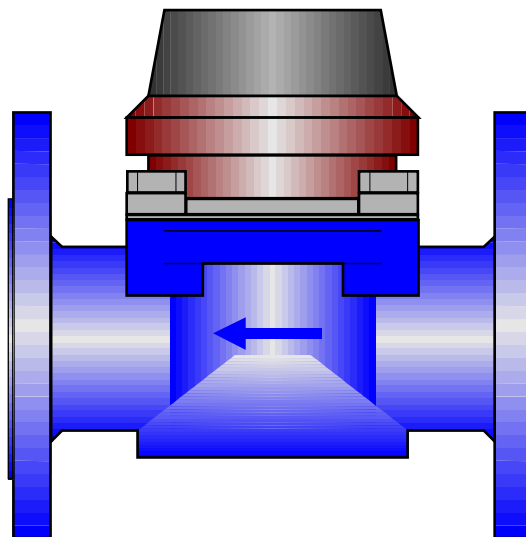

Temperature Probe

Feed Water temperature is measured with a pocketed temperature probe. Installation in the hot end of the hotwell or the Feed pipe is acceptable. This device is loop powered from a 20volt source within the AQ301 control panel and returns a 4-20mA signal. This signal is calibrated as 0 – 110°C.

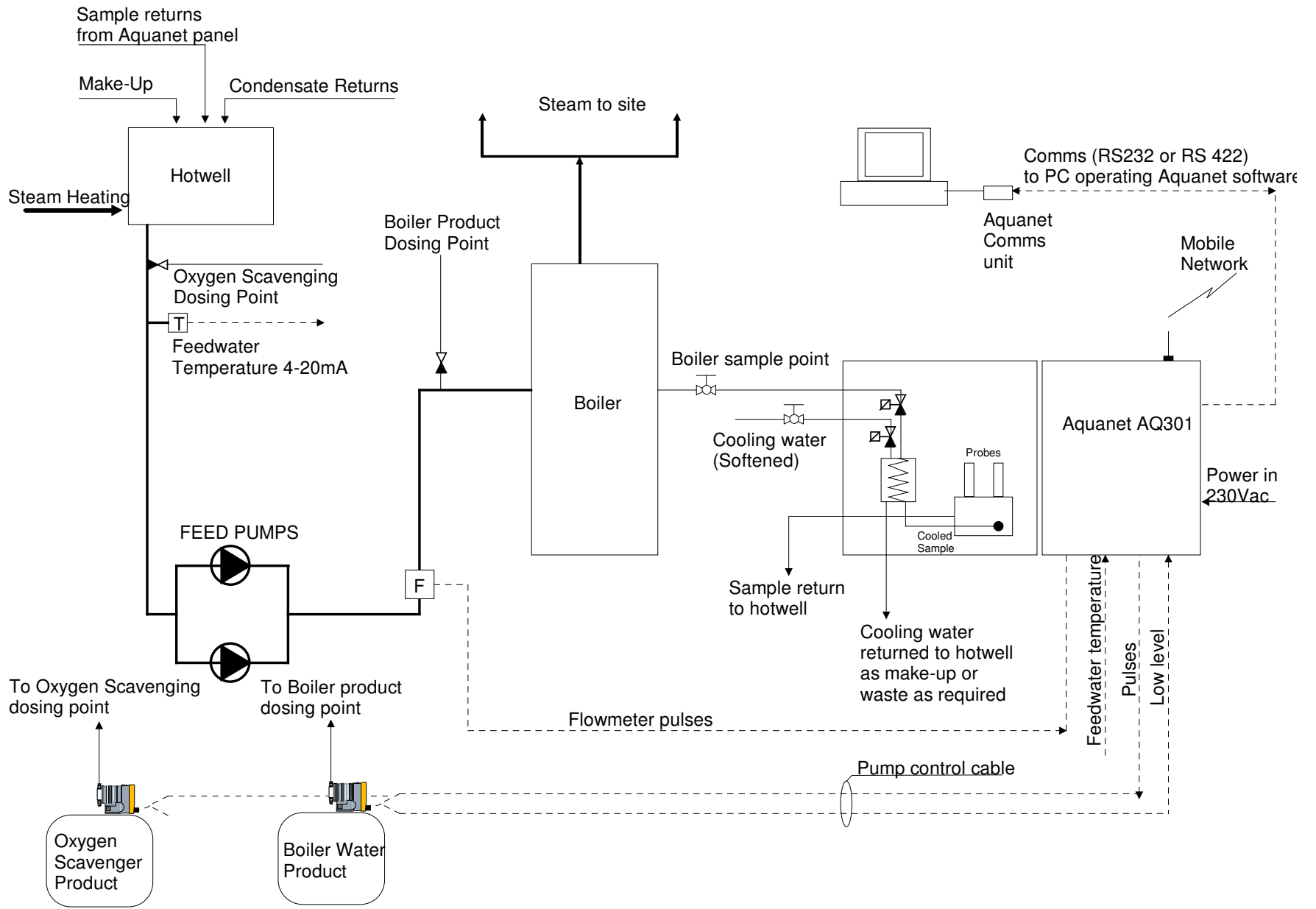

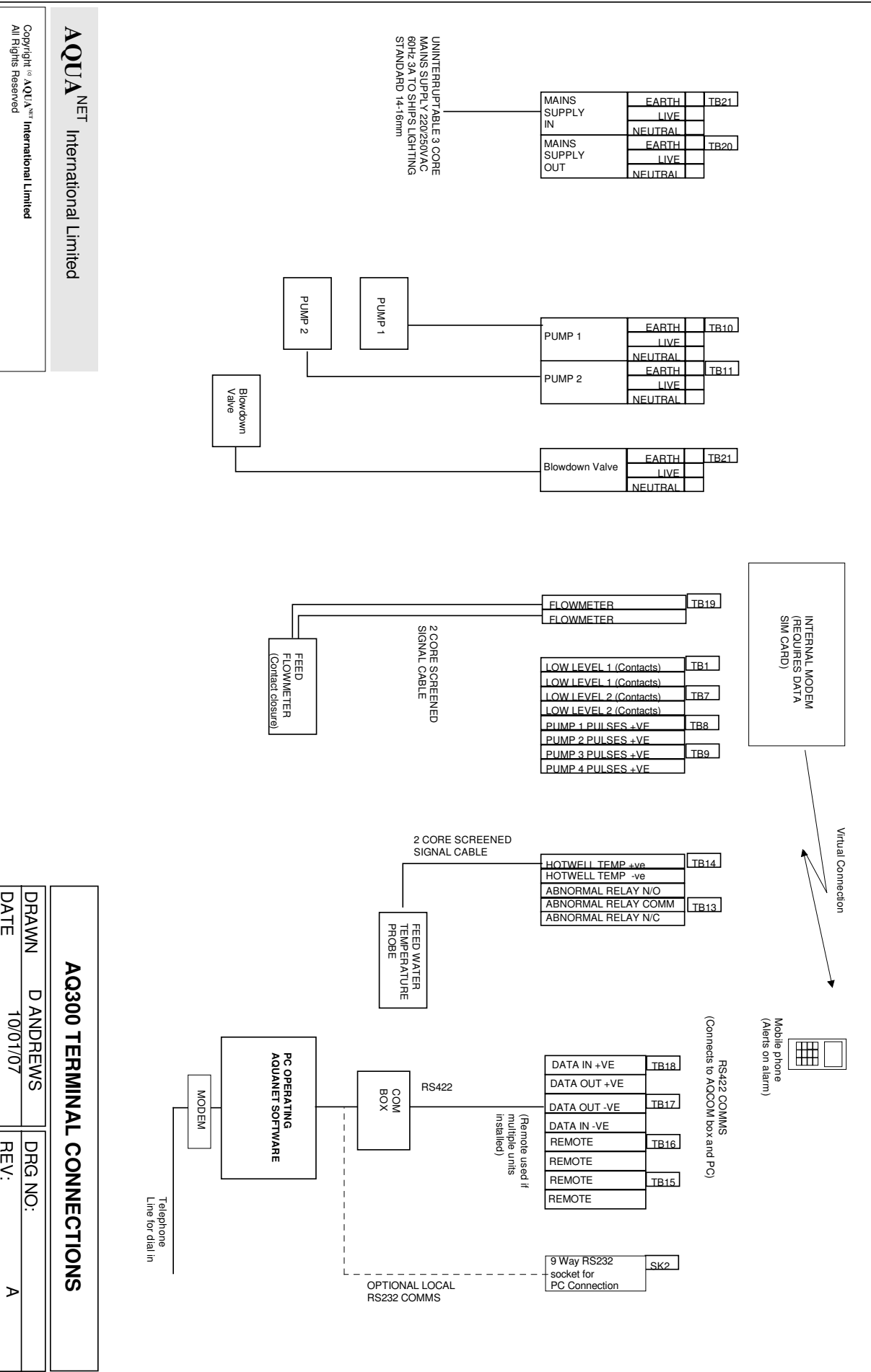

AQUA NET International Limited

Copyright © AQUA NET International Limited
All Rights Reserved

AQ300 TERMINAL CONNECTIONS

DRAWN	D ANDREWS	DRG NO:	
DATE	10/01/07	REV:	A

User Controls.

The panel is equipped with
Indicator LED's
LCD display
Scroll button
Calibrate button
Pump Control Switches

Indicator LEDS.

Sample – Active Green when a sample is taken from the boiler
Blow down –Active Green when the boiler is blowing down.
General Alarm (configurable) – illuminates Red on
Fuse Failure
High sample temp
Temp fail safe
Low chemical

Pump status – Green
Pump pulses- Yellow flash whenever a pulse is sent to the dosing pump.
Product Low Level – Illuminates Red when low level in chemical drum

Pump switches

Off – Controls power to the chemical dosing pump
Manual. - In this position, drive pulses to the chemical dosing pump are controlled by the pump speed control pot (0-100 pulses per minute).
Auto – This is the normal position and the chemicals are dosed according to the feed and boiler water values, ensure the pump stroke is set to 65%
Pump speed control 0 - 100% - works together with Manual pump position

LCD and Scroll button

Pressing the scroll button displays the unit's readings and status in the following order:

pH
Conductivity,
Boiler status (on line or off line)
Feed water temp (in °C)
Sample temperature (in °C)
Manual pump speed settings (in strokes per minute (spm))
Fuse failure indication (as volts where >1.2volts indicates a failure)

Manual Sample

If the scroll button is pressed and held for more than 3 seconds then the boiler sample (and cooling water) valve opens and remains open until the button is released. This allows a manual sample to be taken via the tundish at the sample discharge.

Calibration

- 1.. Isolate the sample using the isolation ball valve in the sample cabinet
- 2.. Remove the probe from the block.
- 3.. Clean probes as necessary, using dilute acid and or detergents, finally wash thoroughly in distilled water.
- 4.. Press the Scroll button repeatedly until the channel to be calibrated is shown on the LCD display.
- 5.. Press Calibrate (to enter the calibration routine).

If the wrong channel is selected then continue to press Scroll to skip the low calibration followed by the high calibration procedure and back to channel select.

- 6.. Place the probe in the low calibration solution/medium.

Note: for pH this is pH 7; for Conductivity the probe is dry and is hanging in air.

- 8.. The display will have the following format 'PROBE IN [XX] PRESS CAL(YYY)'.
When the CAL(YYY) number has stabilised press the Calibrate button.

NOTE : XX is the solution value for the calibration eg 5000 uS and YYY is a number between 0 and 1023 (Bit Count) that represents the value being measured by the probe at the time.

Note :Probes can also be calibrated using AQUAnet software via a connected PC.

Calibration of the pH and conductivity probes are important for accurate operation of the unit
pH should be calibrated every month and conductivity every 3 months
If the

AQUA^{NET} software has the following features:

Displays and Logs

- Feed pH, conductivity, dissolved oxygen and temperature
- Boiler pH, conductivity and dissolved oxygen
- Flow rates for feed to boilers
- Chemical consumption
- Chemical low level status
- Status of system outputs
- Alarm conditions.

Graphs and Logs

- All measured parameters

Direct Control of

- System outputs to control blowdown and solenoid valves.

Calibration of probes

AQUA^{NET} is also used for system configuration changes.

The AQ301 does not rely on AQUA^{NET} software for its normal operation. If the PC running AQUA^{NET} is out of commission the boiler dosing and blowdown will continue to operate regardless.

System Piping and Installation

Boiler sample

Boiler samples are taken from the boilers normal manual sample point via an isolating ball valve, strainer and 6mm stainless steel sample lines.

Cooling Water

Only during a boiler sample does a solenoid valve supply cooling water to the AQ301 cooler.

Cooling water lines are 12 or 15mm copper and are connected to the LT cooling main.

Chemical Dosing Lines

Chemical dosing lines are 6mm Stainless Steel; the dosing arrangement is that the boiler chemical is dosed directly to the drop line as close as possible to the outlet of the hotwell before the feed pumps.

If Amine or a separate oxygen scavenger is being used then this will be dosed close to the feed pumps.

Blow down Valve

Correct blow down is important for chemical balance of the boiler water.

The blow down valve is wired to the terminal rail of the AQ301, the unit is designed for 230Vac operation.

Flow meter

The main flow to the boiler is measured with a normal impeller type hot water flow meter on the boiler's feed line. The flow meter provides contact closure - the contact closure is wired to the AQ301 terminal rail.

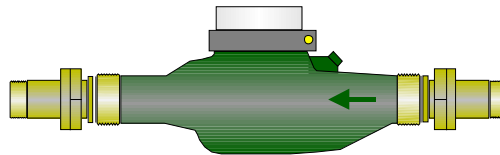

Temperature Probe

Feed Water temperature is measured with a pocketed temperature probe. This device is loop powered from a 20volt source within the AQ301 control panel and returns a 4-20mA signal. This signal is calibrated as 0 – 110°C.

Data Logging System

AQUA^{NET} software operates with Windows XP (in Classic View), or Windows, it is not recommended to operate other software on the AQUA^{NET} PC.

AQUA^{NET} COMM BOX 422*

LED's.

The right LED is the data transmitted light (Tx) and it will flash for every bit of data sent out. The left LED is the data received light (Rx) and it will flash for every bit of data coming in. This LED is also diagnostic and will be on continuously if there is a cable break.

9-Way RS422* Socket

Pin No	Function
1	Alarm Contact NC
2	Alarm Contact Wiper
3	Alarm Contact NO
4	RS422 Data Out -ve
5	RS422 Data Out +ve
8	RS422 Data In -ve
9	RS422 Data In +ve

9 way RS422 socket (Viewed from front)

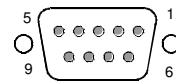

AQUA^{NET} Loop Connections

AQUA^{NET} controllers can be connected into a communications loop. Communications are in ASCII format with a checksum appended to the end of each message.

Units can be wired together to form a loop as shown below.

Data out +ve and -ve from the PC become Data in +ve and -ve to the first unit.

Data out +ve and -ve from the first unit become data in +ve and -ve for the subsequent unit.

A maximum of 20 units may be connected in this way.

General Communications Loop Arrangement

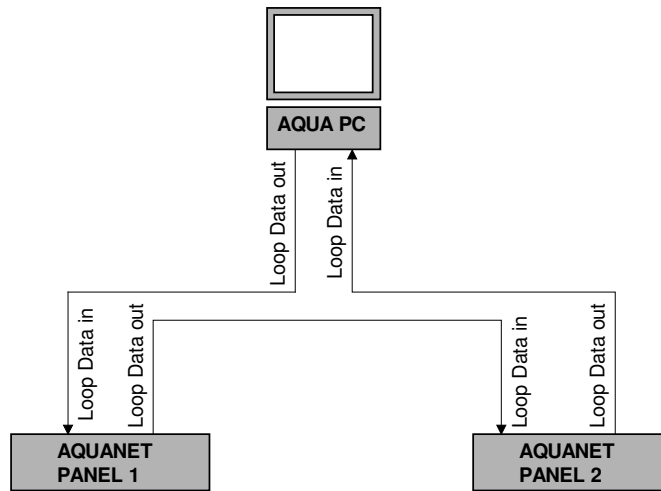

Specific Loop Details

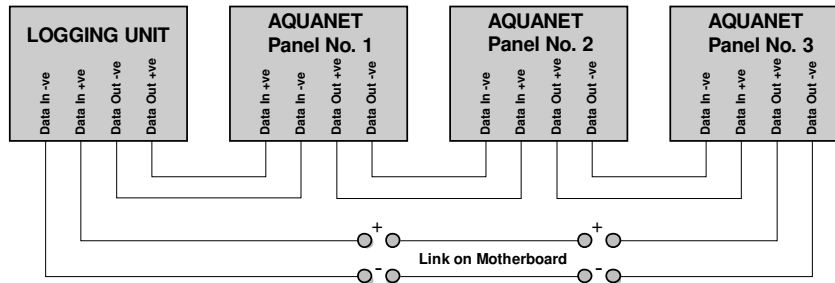

At each unit the data becomes electrically boosted as it is re-transmitted.

The communications interface is electrically and optically isolated from the rest of the electronics associated with the panel or the AQUA PC.

Every AQUA^{NET} panel has a unique 4 character site address. Data is passed from unit to unit. If data is intended for a unit then the unit will recognise its address and append the data requested by the AQUA PC to the end of the message.

Each AQUA^{NET} panel will operate without the communications loop being attached. The communications is used for data logging, engineering maintenance and calibration.

Temperature Probe

Construction

The probe has a stainless steel sheath and an aluminium head.

For maintenance purposes the probe must be mounted in the stainless steel pocket supplied.

This probe has a temperature sensing element mounted 6mm back from its tip.

The wires from this element are taken through the sheath to an amplifier mounted in the head of the probe.

The signal cable is connected to a pair of connections on the amplifier

The amplifier is loop powered from a 20volt source within the AQUA^{NET} control panel and returns a 4-20 mA signal.

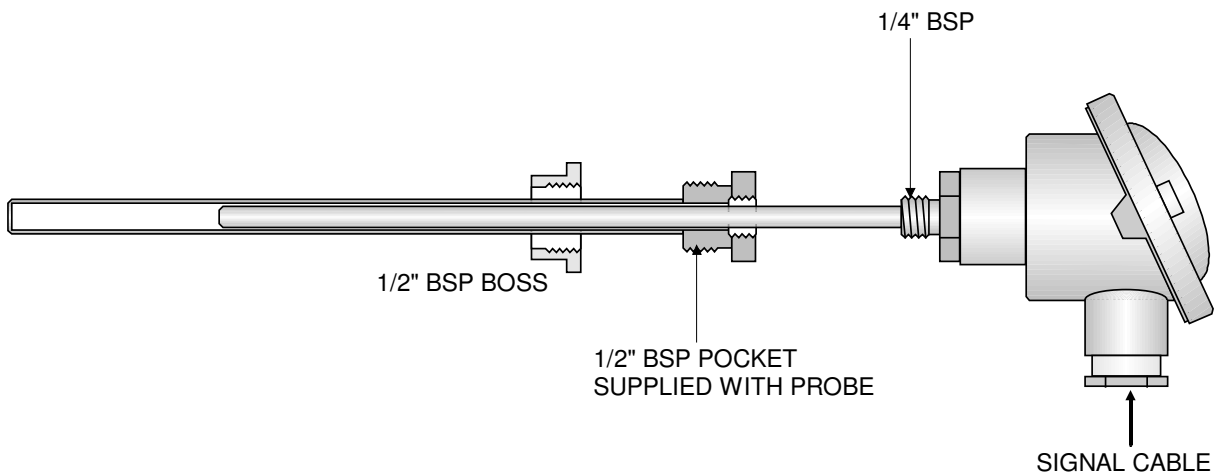

Calibration

The 4-20 mA signal is calibrated as 0 – 110 °C.

Calibration of a temperature probe is normally undertaken initially with a multi-meter on mA range using the 'Z' (zero) and 'S' (span) pots. on the amplifier.

Zero point is set to 4 mA with the probe in melting ice, and the high point is set by adjusting the span to 18.54 mA with the probe in boiling water.

After the physical calibration of the probe has been completed then it is usual to perform a system software calibration using ice and boiling water as low and high calibration AQUA^{NET} solutions.

Calibrations are always undertaken at the factory prior to despatch.

Electrical Installation

Electrical power to the AQUA^{NET} system must be sourced from a clean line on the distribution board.

A dual pole isolator must be fitted to allow periodic system maintenance to be undertaken.

All persons working on the installation must be aware of the combined potential hazards of mains electrical power, water, chemicals, steam and pressure on boiler systems.

Cable specifications

Power Cables	Requirements
Mains power to AQ301	Single phase, 220Vac, 10A 3 core domestic cable
Blow down Valve	Single phase, 220Vac, 3A 3 core domestic cable
AQUA^{NET} PC	Single phase, 220Vac, 3A 3 core domestic cable
Signal Cables	Requirements
Temperature probe	2 core screened instrumentation wire min conductor size 7/0.2mm (24Vdc 20mA max)
Feed flow meter pulses	2 core screened instrumentation wire min conductor size 7/0.2mm (volt free contact closure to digital i/p)
AQUA PC to AQ301	12 core screened instrumentation wire min conductor size 7/0.2mm (Volt-free contact closure to digital i/p)
AQUA ^{NET} loop	Screened twin twisted pair suitable for RS422 communications

System Technical Description

The AQ301 consists of a dual compartment panel measuring 740 x 450 x 170 mm., and a frame which contains the pumps and chemical drums.

The left hand compartment contains solenoid valves, coolers, probes, probe mounting block and a temperature failsafe sensing element.

The right hand compartment contains all the electronics to drive the solenoid valves, sensors, control the dosing pumps and communicate with AQUANET software.

Electronics Panel Description

Front panel mounted display and switches are connected by a ribbon cable to a motherboard which carries most of the switching electronics. The control microprocessors are on the front panel.

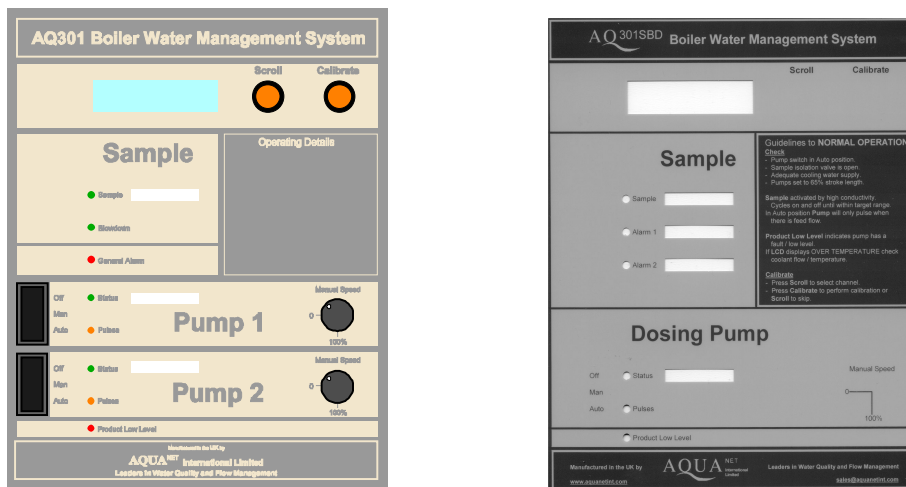

Front Panel Labels

All terminations to the motherboard are achieved by standard screw, 2.5mm rising clamp terminals.

The electronics can be broken down into the following areas.

- pH, Conductivity and DO2 amplifiers
- Power supplies
- Solenoid valve and blow down control solid-state relays
- Pump power switching solid state relays
- Flow meter and temperature interface
- Controller module

Internal wiring is to the following components between the cabinets

- Sample solenoid valve
- Failsafe temperature sensor
- pH probe
- Conductivity probe
- Dissolved oxygen probe

Field wiring from the electronics cabinet to external components are

- Temperature probe
- Blow down valve
- AQUA PC
- Flow meter

The AQ301 controller card is central to the system and has been specifically designed to deal with the problems of water chemistry control.

A card will accept 4-20 mA or 0-2.5 volt input levels from a variety of sources such as:

- pH probes (0-2.5Vdc)
- Conductivity probes (0-2.5Vdc)
- Dissolved oxygen probes (0-2.5Vdc)
- Temperature probes (4-20mA)
- Feed Tank Level controls (switch)
- Flow meters (Pulses)
- Chemical Low Level Indicators (switches)

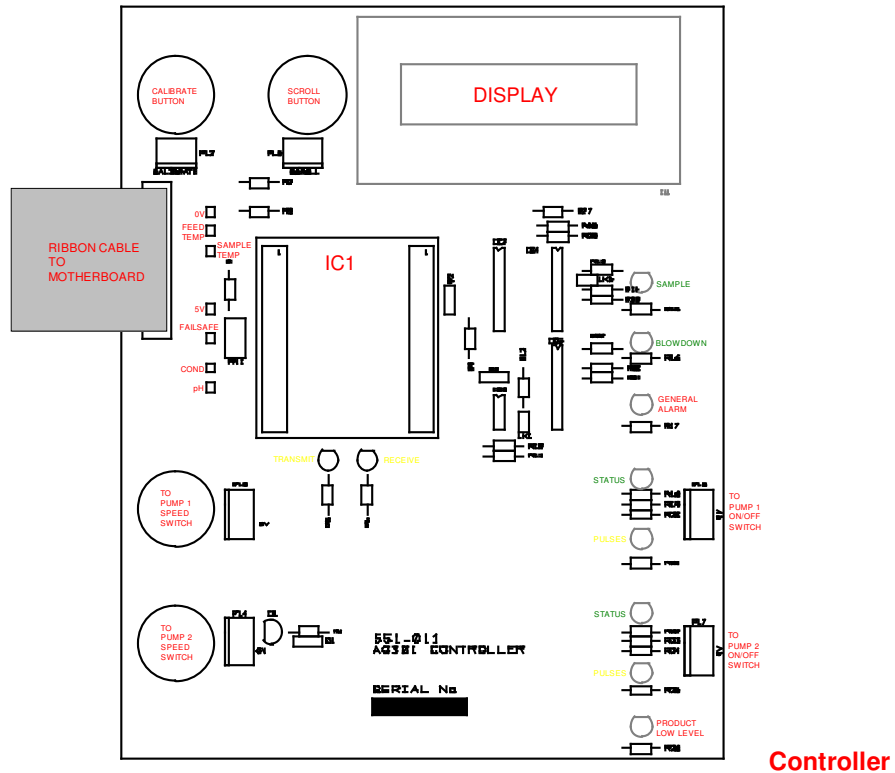

The signals are scaled by the embedded software into appropriate engineering units, from these signals various output lines are driven to control dosing pumps, solenoid valves, blow down valve and alarm relays.

Outputs as well as being driven by any analogue or digital input can also be driven by time or an accumulation of pulses on an input line.

The controller is configurable, it is the combination of setting the correct configuration within the controller and the on board electronics of the AQ301 that allows good control of the boiler water chemistry.

An AQUA^{NET} controller features

- Analogue input lines.
- Digital input lines
- Digital output lines

It is also equipped with an RS422 serial interface and a watchdog circuit to allow automatic system reset in the event of a serious power interruption.

The card is a microprocessor based system and has the following major components.

Microprocessor chips with embedded

RAM – Used for current work space data, volatile on power off

EEPROM – containing all the calibration settings and system timings. (electrically writable).

AtoD - Analog to Digital Converter, converts the signals from pH, conductivity probes etc to digital words for the microprocessor to use in its program.

EPROM – containing the cards operating system (non volatile)

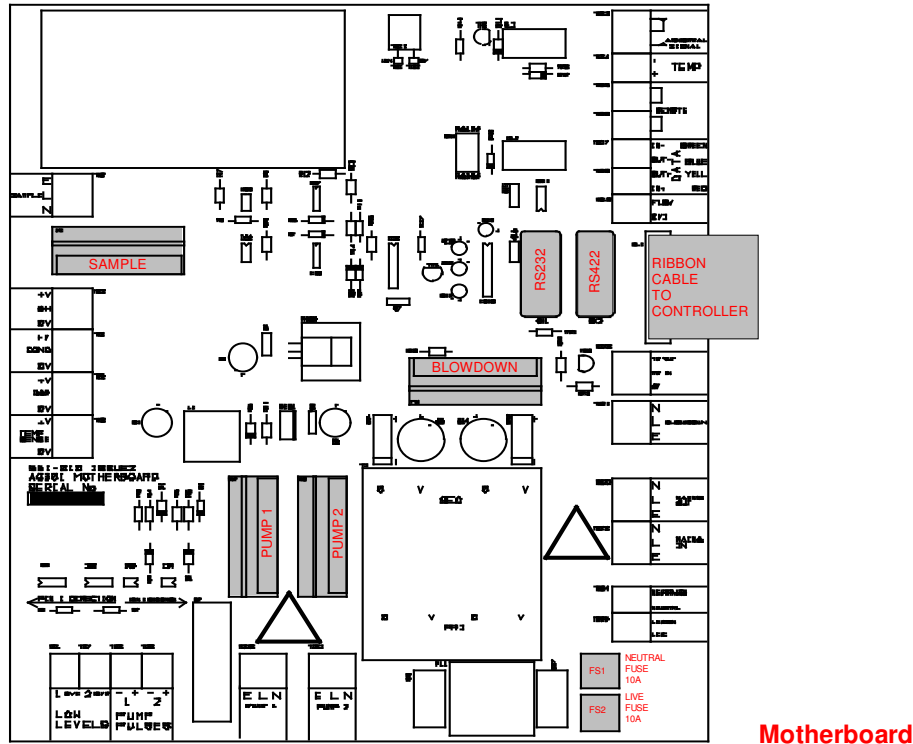

Operation

Correct chemical balance of the boiler system is achieved by dosing the chemicals in accordance with the products specifications as laid down in the product data sheet. Regulation of the system is maintained by controlled operation of the blow down valve. Often product dosage will be dependent on more than one parameter.

The following illustrates the three most common products and the parameters used in dosing and control.

Product

Alkaline Boiler Water Treatment
 Oxygen scavenger either
 or
 Amines

Dosing Parameters.

Boiler feed flow and boiler pH
 Total feed flow and feed dissolved oxygen level
 Total feed flow and feed water temperature
 Condensate pH (or feed pH in systems that have a high condensate return)

AN AQ301 system is very versatile in its configuration ability and it can easily be reprogrammed for alternative chemicals; blow down control is based on the boiler water conductivity. If the conductivity rises above the control set point then the blowdown valve is cycled on and off until the conductivity falls below the set point.

pH Probe

pH probes have a finite life, it is normal practice to replace annually as the glass ages and the internal reference solution becomes depleted.

pH probes provide a very weak signal, the raw signal from the probe is taken to a conditioning amplifier to amplify, scale and offset the signal. This amplifier produces a 0-1.4 volt output this corresponds from pH 0 to pH 14.

The amplifier output signal is then taken via the motherboard to the controller card.

Points to watch out for on a pH probe are contamination of the glass or ceramic junction and damage to the cable.

If a pH probe is suspected of producing an inaccurate signal the course of action is to clean the probe as follows:

1. Visually inspect for broken or cracked glass, invert the probe and look for a bubble indicating that the probe contains reference solution.
2. Periodically soak in ammonia solution for 15 minutes and rub with a soft brush (eg toothbrush).
3. Rinse and soak in the hydrochloric acid supplied for 15 minutes, agitate periodically, and rub with a soft brush
4. Rinse very well under running water.

The probe can then be checked in pH 7 and 10 solution and calibrated as necessary

If the probe does not calibrate then it should be replaced.

pH Probe Amplifier Set-up

(Only to be used if the settings have been inadvertently changed)

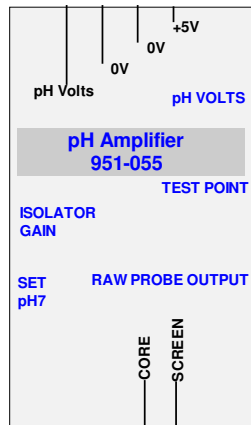

The electronics transmitter module should not require re-setting.

Before embarking on the following procedure ensure that other reasons for drift or inaccuracy have been thoroughly explored.

Instrumentation required.

Multimeter capable of reading 0-2 Volts

ph Probe

pH 10.0 solution

pH 7 solution

Procedure

1. Probe in pH 7.0
2. Monitor SCALED pH with meter set on 0-2.0V range adjust set 7pH for 0.700 volt. (if it is not possible to set pH 7 the probe is defective)
3. Rinse probe and place in pH 10.0 solution
4. Still Monitoring SCALED pH adjust BUFFER potentiometer to read 1.000V.
5. Monitor ISOLATED pH and adjust GAIN potentiometer to read 1.000V.

NOTE:

A pH probe delivers -49mV per pH with pH 7 being 0 mV from effectively a piece of glass having a source impedance of approx 10¹² ohms. Because of the very high source impedance of a pH probe it is not possible to measure this signal directly with a multimeter. The pH amplifier utilises special techniques to measure this signal. Additionally note the pH cable is of a special construction. If it gets wet internally it will short out the raw pH signal and show pH 7 (0mV on the input).

pH cable

A pH signal is a voltage from a very high source impedance, typically 10¹² ohms. As a result the cable used in its construction must be of a high specification to prevent it loading the signal.

The cable consists of a co-axial element to carry the pH voltage signal and a pair of conventional conductors, which are connected to a temperature compensation element. The coaxial element construction is special and if it is to be re-terminated take careful note of the following.

When stripping the coaxial element for terminations it is vital that the black semi-conducting screen, which covers the insulation of the core conductor, is fully peeled back as shown below. If this is not done and it comes in contact with the core conductor then it will short out the pH signal and the probe will read pH7 constantly.

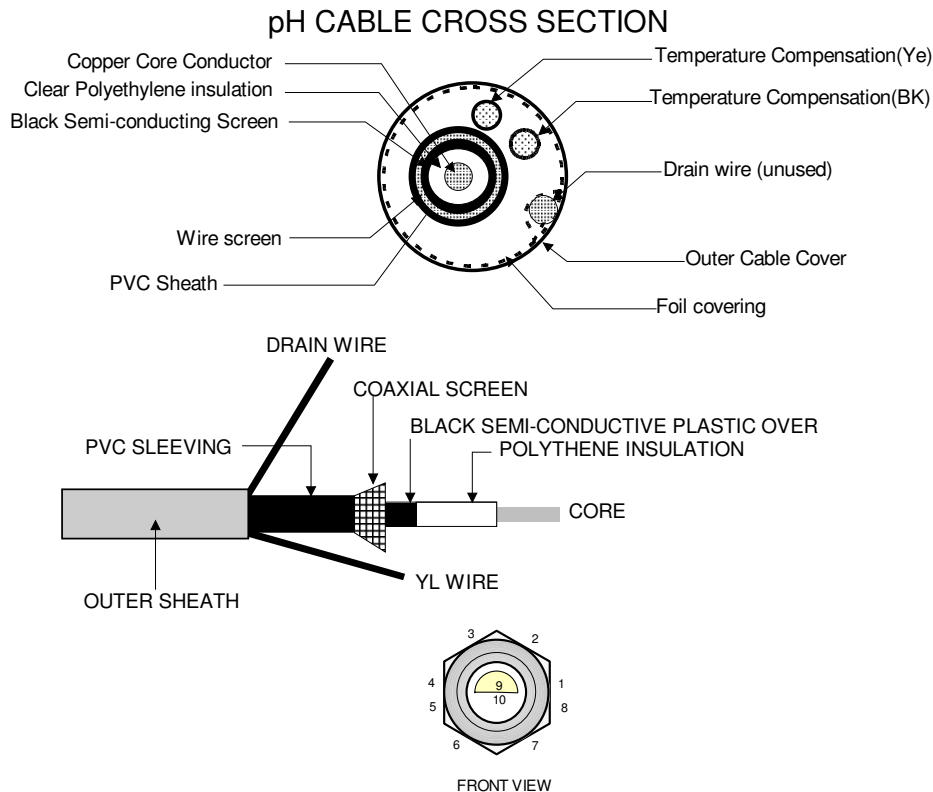

TERMINAL CONNECTIONS

FROM	COLOUR	SIGNAL
1.	UNUSED	
2.	GREEN	OXYGEN OUTPUT 0-10V
3.	BLUE	CALIBRATION
4.	UNUSED	
5.	RED	-15VOLTS
6.	WHITE	+15VOLTS
7.	BLACK	POWER GND
8.	UNUSED	
9.	UNUSED	
10.	YELLOW	CALIBRATION

NOTE: Take great care soldering this cable as the polythene melts easily and if damaged the probe will not function.

Conductivity Probe

A conductivity probe injects an electrical signal into the sample of the boiler water. The amplitude of this signal is measured and scaled to a 0-2.5 volt signal to correspond to a conductivity of 0 to the max conductivity in microSiemens or uS.

(Note conductivity is sometimes referred to as the older unit name of microMhos or uMho. The terms are interchangeable and no additional scaling is required).

The amplifier output signal is then taken via the motherboard to the controller card.

If a conductivity probe is suspected of producing an inaccurate signal the course of action is as follows.

1. Visually inspect for broken electrodes or cracked body, check the cable.
2. Soak in ammonia solution for 15 minutes and rub with a soft brush.
3. Rinse and soak in the hydrochloric acid for 15 minutes, agitate periodically.
4. Rinse very well under running water.

(Do not scrub the electrodes with emery or anything abrasive as this will change the geometry and the probes cell constant).

The probe can then be checked in air (zero conductivity) and then in standard solution (eg 1413 uS or 120uS in high pressure boilers) and calibrated as necessary.

If the probe does not calibrate and there is no physical damage to the probe or cable it is good practice to follow the amplifier setting up procedure to identify the fault.

A check with a multimeter on the output of the conductivity amplifier generally identifies any problems.

Signal values of 0V in air and less than 2.5 Vdc in a calibration solution are to be expected.

2.5 to 4.5 Vdc is indeterminate and normally indicates that the module set-up has been tampered with.

Greater than 4.5Vdc will indicate a serious failure of the conductivity module. The probe contains a temperature compensation element which at 25C has a value of 10K ohms.

Conductivity Amplifier Set-up

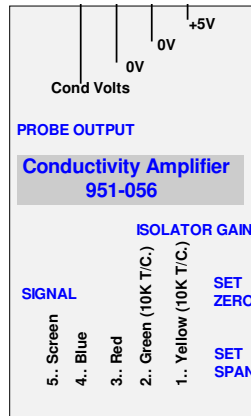

1. With probe in air monitor LK2 (Signal) with meter; adjust RV4 (set Zero) for 0.000Volt.
2. With probe in 1413 solution, allow temperatures to stabilise for 5 minutes, ensure that the probe is supported in the centre of the pot containing the solution.
3. Adjust the (Span) potentiometer for a reading of 1.413V on LK2
4. Monitor LK1 (Isolated signal) and adjust RV3 (Gain) potentiometer to read 1.413 V

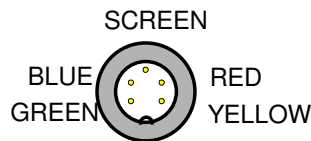

5 WAY CABLE PLUG
(VIEW ON PINS SHOWING
WIRE COLOURS)

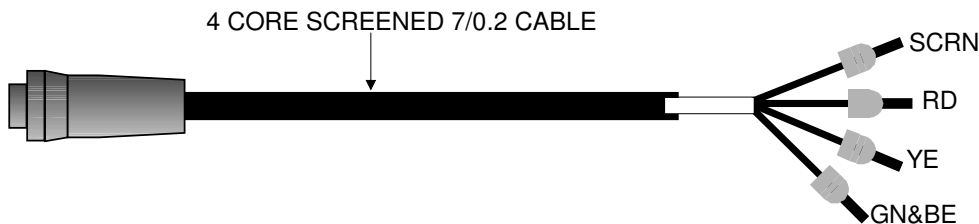

Cable Functions

Red	Probe
Green	Probe
Blue	10K Thermistor
Yellow	10K Thermistor

Solid State Relays with Fuse Failure Detection

These devices switch AC voltage to a maximum of 3 amps. They are opto-isolated and switch at the zero crossing point of the mains cycle.

The logic side requires 5 volts (pin 5) and the mains side requires the live side of the supply (pin2) to be fed to it.

Operation is simple, if connected correctly into the circuit card and 5 volts is present on the +5V pin, when the control pin (pin 6) is taken to zero volts the AC IN will be switched to the load (AC OUT).

If the fuse fails the LED will glow continuously until the detection is accepted and the fuse replaced.

Identification

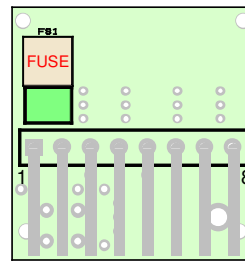
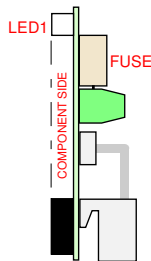
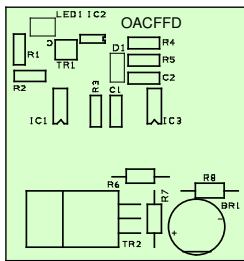

PIN CONNECTIONS	
1.	AC OUT
2.	AC IN
3.	NEUTRAL
4.	MAINSDET-PGD
5.	+5V
6.	CONTROL-PGD
7.	0V
8.	STATUS