

# Condensate Monitoring just got better

Remote condensate monitoring in real time is just one of the mandatory requirements for facilitating unmanned boilerhouse operation for up to 72 hours.

By re-thinking the way in which condensate can be sampled directly from the line and harnessing the latest advances in telemetry, the C4S-RCM1 (single point) and C4S-RCM5 (multi-point) condensate monitoring systems from **controls4steam** offer a simpler, more accurate and cost-effective way to help maintain optimum boiler performance and compliance with all current legislation.

## Sampling made simple

A key feature of both systems is the twin-tipped stainless steel probe with integral temperature compensation. Conductivity varies with temperature at 2%/°C and as condensate flow rates and temperatures vary with plant load, even a 5°C difference will lead to a +/- 10% error on uncompensated systems.

The unique sensor screws into a housing inserted directly into the condensate line enabling it to be removed for inspection and cleaning. The probe can be removed without having to bypass or shut down the line. What's more, because the probe is sampling directly from the condensate line there is no need for a bypass line or isolation ball valves, thus reducing the number of components, the associated maintenance costs and the space required for the installation.

Accuracy is improved because the probe is continually sampling directly from the condensate line in real time.

The photograph on the right shows a probe (circled) fitted directly to a condensate line.

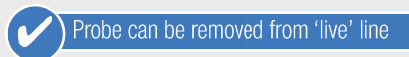
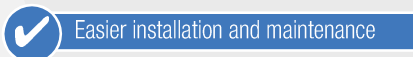
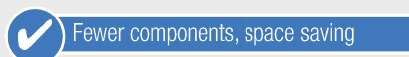
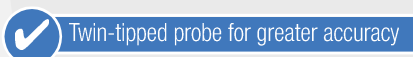

## Tipped for greater accuracy

The twin tipped probe takes readings over a fixed distance offering enhanced accuracy of the conductivity reading, since it is not subject to variable resistance in the circuit created by line components, as is generally the case with other probes.

The illustration shows the components of the conductivity probe. Its unique design enables it to be removed from a 'live' condensate line for calibration against a laboratory standard without the need for diversion or shutdown.

This ensures greater accuracy of the conductivity reading.

Please contact **controls4steam** for a full technical specification of all C4S-RCM1 and/or C4S-RCM5 system components.

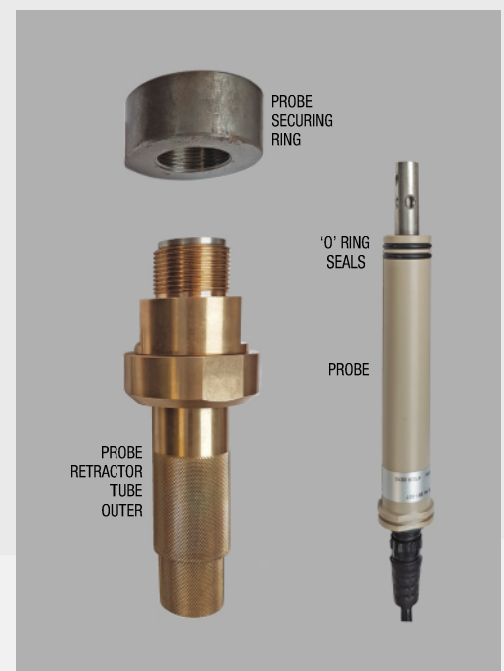

Temperature compensation curve: 2%/°C  
Operational range: 20 to 150°C  
Maximum operating pressure: 10 bar

## C4S-RCM1 (single point)

The C4S-RCM1 comprises a probe and retractable housing, probe amplifier and control unit.

The latter comprises an intuitive user interface with a two push-button controlled LCD scrollable display that is used to set alarm set-point triggers as well as providing system status and real-time condensate probe readings. The C4S-RCM1 can be used as a stand-alone system or integrated into a comprehensive boiler control system using Modbus communication protocols via proprietary Aquanet system software.

Aquanet software is also used for calibrating the probe(s).

- ✓ Clear, concise user interface
- ✓ Real-time data from condensate line

- ✓ Integration with boiler control systems
- ✓ Uses proven Aquanet software

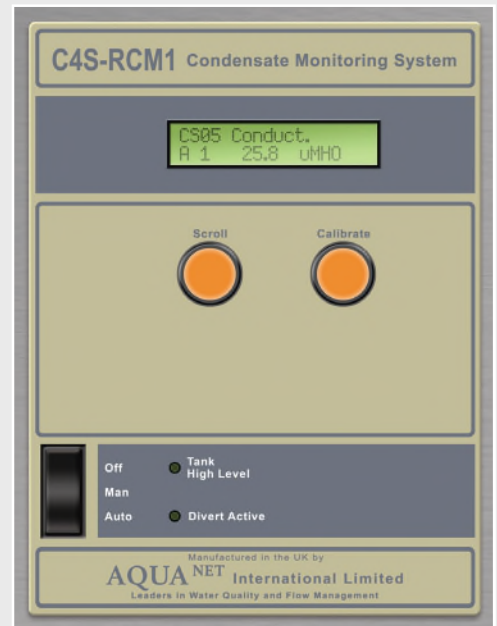

## C4S-RCM5 (multi-point)

Utilising the same twin-tipped probe technology found on the C4S-RCM1, the C4S-RCM5 allows up to eight separate probes to be connected to a single condition monitoring panel.

The system is ideal for use in plants where multiple processes share a single boiler feed. By monitoring the condition of condensate at each process, any suspected contamination can immediately be pinpointed and isolated, enabling the remainder of the plant to stay operational. This also eliminates the need to dump the entire condensate line and the resulting loss of costly chemically treated boiler water or useful heat.

For large-scale installations two or more C4S-RCM5 control panels can be linked in a communications loop, which in turn can interface with an optional PC for data logging using the proprietary Aquanet software.

The C4S-RCM5 monitoring board comprises a scrollable LCD display for individual probe readings as well as up to eight permanent status displays with hi/lo configurable event alarms and corrective actions. Optional sirens and/or beacons can be provided to signal alerts.

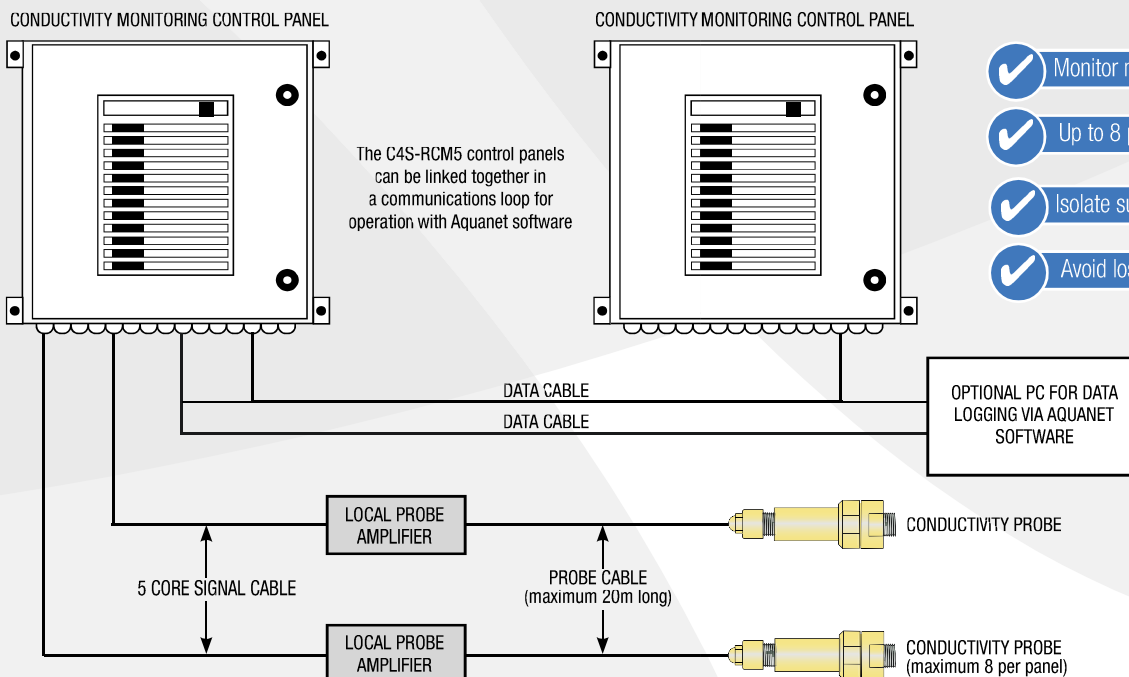

- ✓ Monitor multiple processes
- ✓ Up to 8 probes per panel (expandable)
- ✓ Isolate suspect contamination
- ✓ Avoid loss of treated boiler water

Schematic of a C4S-RCM5 multi-point condensate monitoring system